

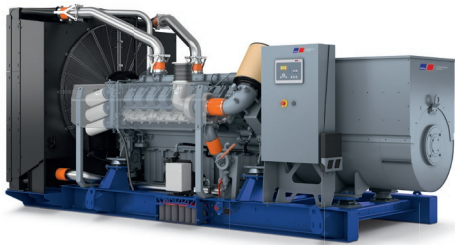

## Diesel Generator Set

# MTU 16V2000 DS1000

380V - 415V/50 Hz/prime/fuel consumption optimized  
16V2000G16F/air charge air cooling



Optional equipment and finishing shown. Standard may vary.

## Product highlights

### Benefits

- Low fuel consumption
- Optimized system integration ability
- High reliability and availability of power
- Long maintenance intervals
- Optimized ratio between size and power
- Wide operating range without derating

### Support

- Global product support offered

### Standards

- Engine-generator set is designed and manufactured in facilities certified to standards ISO 2008:9001 and ISO 2004:14001
- Generator set complies to G3 according to ISO 8528
- Generator meets NEMA MG1, BS5000, ISO, DIN EN and IEC standards
- NFPA 110

### Power rating

- System rating: 910 kVA
- Accepts rated load in one step per NFPA 110
- Generator set complies to G3 according to ISO 8528-5
- Generator set exceeds load steps according to ISO 8528-5

### Performance assurance certification (PAC)

- Engine-generator set tested to ISO 8528-5 for transient response
- 75% load factor for prime power applications
- Verified product design, quality and performance integrity
- All engine systems are prototype and factory tested

### Complete range of accessories available

- Control panel
- Power panel
- Fuel system
- Fuel connections with shut-off valve mounted to base frame
- Starting/charging system
- Exhaust system
- Mechanical radiator
- Oversized voltage alternators

### Emissions

- Fuel consumption optimized
- TA-Luft, Tier 2 compliant and NEA (ORDE) optimization optionally available

### Certifications

- CE certification option
- VDE4110 Certification



A Rolls-Royce  
solution

## Application data <sup>1)</sup>

Engine	Fuel consump. opt.	Emission opt. <sup>2)</sup>	Cooling/radiator system	Fuel consump. opt.	Emission opt. <sup>2)</sup>
Manufacturer	MTU	MTU	Coolant flow rate (HT circuit): m <sup>3</sup> /hr	41.6	41.6
Model	16V2000G16F	16V2000G16F	Heat rejection to coolant: kW	340	325
Type	4-cycle	4-cycle	Heat radiated to charge air cooling: kW	115	170
Arrangement	16V	16V	Heat radiated to ambient: kW	40	40
Displacement: l	35.7	35.7	Fan power for mech. radiator (40°C):	43.4	43.4
Bore: mm	135	135	Fan power for mech. radiator (50°C):	43.4	43.4
Stroke: mm	156	156	Air flow required for mech. radiator (40°C)		
Compression ratio	17.5	17.5	cooled unit: m <sup>3</sup> /min	1462	1462
Rated speed: rpm	1500	1500	Air flow required for mech. radiator (50°C)		
Engine governor	ADEC	ADEC	cooled unit: m <sup>3</sup> /min	1462	1462
Speed regulation	± 0.25%	± 0.25%	Engine coolant capacity		
Max power: kWm	806	806	(without cooling equipment): l	70	70
Mean effective pressure: bar	18.1	18.1	Radiator coolant capacity (40°C): l	74	74
Air cleaner	dry	dry	Radiator coolant capacity (50°C): l	106	106
			Max. coolant temperature (warning): °C	102	102
			Max. coolant temperature (shutdown): °C	105	105
<b>Fuel system</b>			<b>Exhaust system</b>		
Maximum fuel lift: m	5	5	Exhaust gas temp. (after turbocharger): °C	540	520
Total fuel flow: l/min	30	30	Exhaust gas volume: m <sup>3</sup> /s	2.5	2.85
<b>Fuel consumption <sup>2)</sup></b>			Maximum allowable back pressure: mbar	50	50
At 100% of power rating: l/hr g/kWh	186/192	196/202	Minimum allowable back pressure: mbar	30	30
At 75% of power rating: l/hr g/kWh	142/195	150/206			
At 50% of power rating: l/hr g/kWh	99/204	104/214			
<b>Lube oil system</b>			<b>Generator</b>		
Total oil system capacity: l	102	102	Protection class	IP23	IP23
Max. lube oil temp. (alarm): °C	103	103	Insulation class	H	H
Max. lube oil temp. (shutdown): °C	105	105	Voltage regulation (steady state)	± 0.25%	± 0.25%
Min. lube oil pressure (alarm): bar	4.5	4.5	Rado interference class	N	N
Min. lube oil pressure (shutdown): bar	4	4			
<b>Combustion air requirements</b>					
Combustion air volume: m <sup>3</sup> /s	0.93	1.10			
Max. air intake restriction: mbar	40	40			

1 All data refers only to the engine and is based on ISO standard conditions (25°C and 100m above sea level).

2 Emission optimized data refer to TA-Luft optimized and NEA (ORDE) optimized/Tier 2 compliant engines.

## Standard and optional features

### System ratings (kW/kVA)

Generator model	Voltage	with mechanical radiator**		
		kWel	kVA*	AMPS
Leroy Somer LSA 49.3 L10 (Low voltage Leroy Somer standard)	380 V	728	910	1383
	400 V	728	910	1313
	415 V	728	910	1266
Leroy Somer LSA 50.2 M6 (Low voltage Leroy Somer oversized)	380 V	728	910	1383
	400 V	728	910	1313
	415 V	728	910	1266
Marathon 740RSL7183 (Low voltage Marathon standard)	380 V	728	910	1383
	400 V	728	910	1313
	415 V	728	910	1266
Marathon 742RSL7185 (Low voltage Marathon oversized)	380 V	728	910	1383
	400 V	728	910	1313
	415 V	728	910	1266

\* cos phi = 0.8

\*\* BE, fuel optimized: max. power available up to: open power unit 40°C/400m; TAL, EPA Tier 2 compl., NEA: standard operating conditions/open power unit 25°C/100m  
Electrical outputs may vary depending on generator voltage and ambient conditions. For power outputs consult your MTU dealer.

Intake air depression/mbar: 15mbar

Exhaust back pressure/mbar: 30mbar

### Engine

- 4-Cycle
- Standard single stage air filter
- Oil drain extension & shut-off valve
- Full flow oil filters
- Closed crankcase ventilation
- ADEC electronic isochronous engine governor
- Common rail fuel injection
- Dry exhaust manifold
- Electric starting motor (24V)
- Fuel consumption optimized engine
- TA-Luft optimized engine
- Tier 2 optimized engine
- NEA (ORDE) optimized engine

### Generator

- Leroy Somer low voltage generator
- Meets NEMA MG1, BS5000, IEC 60034-1, VDE 0530, DIN EN 12601, AS1359 and ISO 8528 requirements
- Superior voltage waveform
- Solid state, volts-per-Hertz regulator
- 4 pole three-phase synchronous generator
- Brushless, self-excited, self-regulating, self-ventilated
- Digital voltage regulator
- Anti condensation heater
- Stator winding Y-connected, accessible neutral (brought out)
- Protection IP 23
- less than 5% harmonic distortion
- 2/3 pitch stator windings
- No load to full load regulation
- ± 0.25% voltage regulation no load to full load
- Insulation class H, utilization acc. to H
- Radio suppression EN55011, group 1, cl. B
- Short circuit capability 3xIn for 10sec
- Sustained short circuit current of up to 300% of the rated current for up to 10 seconds (Leroy Somer generator)
- Winding and bearing RTDs (without monitoring)
- Excitation by AREP + PMI
- Mounting of CT's: 3x 2 core CT's
- Voltage setpoint adjustment ±10V
- Sustained short circuit current of up to 250% of the rated current for up to 10 seconds (Marathon generator)
- Marathon low voltage generator
- Oversized generator

Represents standard features

Represents optional features

## Standard and optional features

### Cooling system

- Jacket water pump
- Thermostat(s)
- Air charge air cooling
- Mechanical radiator
- Jacket water heater

### Control Panel

- Pre-wired control cabinet for easy application of customized controller (V1+)
- Island operation (V2)
- Automatic mains failure operation with ATS (V3a)
- Automatic mains failure operation incl. control of generator and mains breaker (V3b)
- Island parallel operation of multiple gensets (V4)
- Automatic mains failure operation with short (< 10s) mains parallel overlap synchronization (V5)
- Mains parallel operation of a single genset (V6)
- Mains parallel operation of multiple gensets (V7)
- Basler controller
- Deif controller
- Complete system metering
- Digital metering
- Engine parameters
- Generator protection functions
- Engine protection
- SAE J1939 engine ECU communications
- Parametrization software
- Multilingual capability
- Multiple programmable contact inputs
- Multiple contact outputs
- Event recording
- IP 54 front panel rating with integrated gasket
- Different expansion modules
- Remote annunciator
- Daytank control
- Generator winding temperature monitoring
- Generator bearing temperature monitoring
- Differential protection with multi-function protection relay
- Modbus RTU-TCP gateway

### Power Panel

- Available in 600x600
- Phase monitoring relay 230V/400V
- Supply for battery charger
- Supply for jacket water heater
- Plug socket cabinet for 230V compatible Euro

### Fuel system

- Flexible fuel connectors mounted to base frame
- Fuel filter with water separator
- Switchable fuel filter with water separator
- Fuel cooler

### Starting/charging system

- 24V starter
- Starter batteries, cables, rack, disconnect switch
- Battery charger
- Redundant starter 2x7.5KW

### Mounting system

- Welded base frame
- Resilient engine and generator mounting
- Modular base frame design

### Exhaust system

- Exhaust bellows with connection flange
- Exhaust silencer with 10 dB(A) sound attenuation
- Exhaust silencer with 30 dB(A) sound attenuation
- Exhaust silencer with 40 dB(A) sound attenuation
- Y-connection-pipe

Represents standard features

Represents optional features

## Weights and dimensions

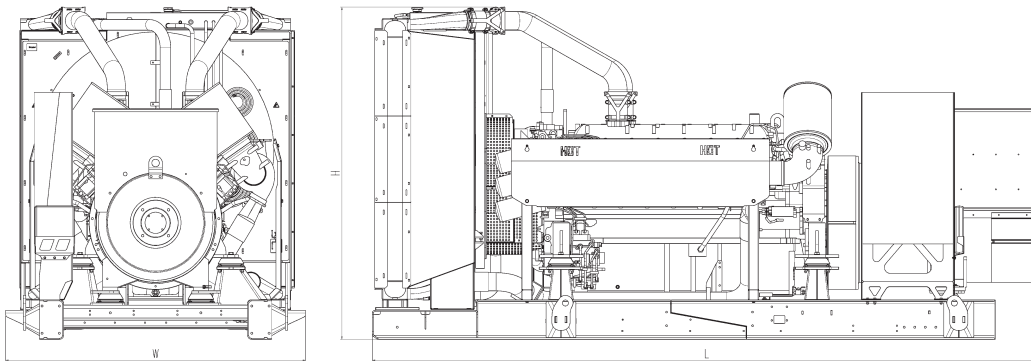

Drawing above for illustration purposes only, based on a standard open power 400 Volt engine-generator set. Lengths may vary with other voltages. Do not use for installation design. See website for unit specific template drawings.

System	Dimensions (L x W x H)	Weight (dry/less tank)
Open power unit (OPU)	4440 x 1990 x 2200 mm	6550 kg

Weights and dimensions are based on open power units and are estimates only. Consult the factory for accurate weights and dimensions for your specific engine-generator set.

## Sound data

– Consult your local MTU distributor for sound data.

## Emissions data

– Consult your local MTU distributor for emissions data.

## Rating definitions and conditions

- Prime power ratings apply to installations where utility power is unavailable or unreliable. At varying load, the number of generator set operating hours is unlimited. A 10% overload capacity is available for one hour in twelve. Ratings are in accordance with ISO 8528-1, ISO 3046-1, BS 5514 and AS 2789.  
Average load factor:  $\leq 75\%$ . Operating hours/year: unlimited
- Consult your local MTU distributor for derating information.