

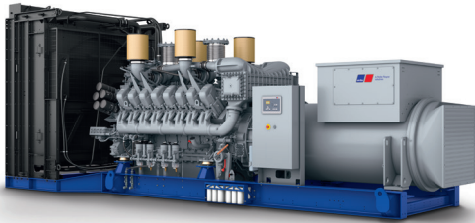

## Diesel Generator Set

# MTU 16V4000 DS2500

380V – 11 kV/50 Hz/grid stability power/fuel consumption optimized/  
16V4000G24F/water charge air cooling



Optional equipment and finishing shown. Standard may vary.

## Product highlights

### Benefits

- Low fuel consumption
- Optimized system integration ability
- High reliability
- High availability of power
- Long maintenance intervals

### Support

- Global product support offered

### Standards

- Engine-generator set is designed and manufactured in facilities certified to standards ISO 2008:9001 and ISO 2004:14001
- Generator set complies to ISO 8528
- Generator meets NEMA MG1, BS5000, ISO, DIN EN and IEC standards
- NFPA 110

### Power rating

- System ratings: 2120 kVA - 2550 kVA
- Accepts rated load in one step per NFPA 110
- Generator set complies to G3 according to ISO 8528-5
- Generator set exceeds load steps according to ISO 8528-5

### Performance assurance certification (PAC)

- Engine-generator set tested to ISO 8528-5 for transient response
- 100% load factor
- Verified product design, quality and performance integrity
- All engine systems are prototype and factory tested

### Complete range of accessories available

- Control panel
- Power panel
- Circuit breaker/power distribution
- Fuel system
- Fuel connections with shut-off valve mounted to base frame
- Starting/charging system
- Exhaust system
- Mechanical and electrical driven radiators
- Medium and oversized voltage alternators

### Emissions

- Fuel consumption optimized

### Certifications

- CE certification option
- Unit certificate acc. to BDEW (German Grid-Code)



A Rolls-Royce  
solution

## Application data <sup>1)</sup>

### Engine

Manufacturer	MTU
Model	16V4000G24F
Type	4-cycle
Arrangement	16V
Displacement: l	76.3
Bore: mm	170
Stroke: mm	210
Compression ratio	16.4
Rated speed: rpm	1500
Engine governor	ECU 9
Max power: kWm	1965
Air cleaner	Dry

### Fuel system

Maximum fuel lift: m	5
Total fuel flow: l/min	20

### Fuel consumption <sup>2)</sup>

	l/hr	g/kwh
At 100% of power rating:	447.5	189
At 75% of power rating:	339.1	191
At 50% of power rating:	237.9	201

### Liquid capacity (lubrication)

Total oil system capacity: l	300
Engine jacket water capacity: l	175
Intercooler coolant capacity: l	50

### Combustion air requirements

Combustion air volume: m <sup>3</sup> /s	2.3
Max. air intake restriction: mbar	50

### Cooling/radiator system

Coolant flow rate (HT circuit): m <sup>3</sup> /hr	68.5
Coolant flow rate (LT circuit): m <sup>3</sup> /hr	30
Heat rejection to coolant: kW	730
Heat radiated to charge air cooling: kW	320
Heat radiated to ambient: kW	90
Fan power for electr. radiator (40°C): kW	44

### Exhaust system

Exhaust gas temp. (after turbocharger): °C	485
Exhaust gas volume: m <sup>3</sup> /s	5.8
Maximum allowable back pressure: mbar	85
Minimum allowable back pressure: mbar	30

## Standard and optional features

### System ratings (kW/kVA)

Generator model	Voltage	Fuel consumption optimized					
		without radiator			with mechanical radiator		
		kWel	kVA*	AMPS	kWel	kVA*	AMPS
Leroy Somer LSA52.3 L12 (Low voltage Leroy Somer standard)	380 V	1888	2360	3586	1840	2300	3494
	400 V	1888	2360	3406	1840	2300	3320
	415 V	1888	2360	3283	1840	2300	3200
Marathon 744RSL7092 (Low voltage Marathon)	380 V	1752	2190	3327	1752	2190	3327
	400 V	1824	2280	3291	1816	2270	327
	415 V	1696	2120	2949	1696	2120	2949
Marathon 1020FDL7093 (Low voltage Marathon oversized)	380 V	1752	2190	3327	1752	2190	3327
	400 V	1824	2280	3291	1816	2270	3276
	415 V	1696	2120	2949	1696	2120	2949
Marathon 1020FDH7099 (Medium volt. marathon)	11 kV	2040	2550	134	1832	2290	120
Leroy Somer LSA53.2 XL11 (Medium volt. Leroy Somer)	11 kV	1880	2350	123	1840	2300	121

\* cos phi = 0.8

1 All data refers only to the engine and is based on ISO standard conditions (25°C and 100m above sea level).

2 Values referenced are in accordance with ISO 3046-1. Conversion calculated with fuel density of 0.83 g/ml. All fuel consumption values refer to rated engine power.

## Standard and optional features

### Engine

- 4-Cycle
- Standard single stage air filter
- Oil drain extension & shut-off valve
- Closed crankcase ventilation with improved oil separator
- Governor-electronic isochronous
- Common rail fuel injection
- Fuel consumption optimized engine
- Centrifugal oil filter

### Generator

- 4 pole three-phase synchronous generator
- Brushless, self-excited, self-regulating, self-ventilated
- Digital voltage regulator
- Anti condensation heater
- Stator winding Y-connected, accessible neutral (brought out)
- Protection IP23
- Insulation class H, utilization acc. to H
- Radio suppression EN55011, group 1, cl. B
- Short circuit capability  $3 \times I_n$  for 10sec
- Winding and bearing RTDs (without monitoring)
- Excitation by AREP
- Mounting of CT's: 2 core CT's
- Winding pitch: 2/3 winding
- Voltage setpoint adjustment  $\pm 10\%$
- Meets NEMA MG-1, BS 5000, IEC 60034-1, VDE 0530, DIN EN 12601, AS1359 and ISO 8528 requirements
- Leroy Somer low voltage generator
- Marathon low voltage generator
- Oversized generator
- Medium voltage generator

### Cooling system

- Jacket water pump
- Thermostat(s)
- Water charge air cooling
- Mechanical radiator
- Electrical driven front-end cooler
- Jacket water heater

### Control panel

- Pre-wired control cabinet for easy application of customized controller (V1+)
- Island operation (V2)
- Automatic mains failure operation with ATS (V3a)
- Automatic mains failure operation incl. control of generator and mains breaker (V3b)
- Island parallel operation of multiple gensets (V4)
- Automatic mains failure operation with short (< 10s) mains parallel overlap synchronization (V5)
- Mains parallel operation of a single genset (V6)
- Mains parallel operation of multiple gensets (V7)
- Basler controller
- Deif controller
- Complete system metering
- Digital metering
- Engine parameters
- Generator protection functions
- Engine protection
- SAE J1939 engine ECU communications
- Parametrization software
- Multilingual capability
- Multiple programmable contact inputs
- Multiple contact outputs
- Event recording
- IP 54 front panel rating with integrated gasket
- Different expansion modules
- Remote annunciator
- Daytank control
- Generator winding temperature monitoring
- Generator bearing temperature monitoring
- Modbus TCP-IP

### Power panel

- Available in 600x600 and 600x1000
- Phase monitoring relay 230V/400V
- Supply for battery charger
- Supply for jacket water heater
- Supply for anti condensation heating
- Plug socket cabinet for 230V compatible Euro/USA
- Supply for electrical driven radiator from 45kW - 75kW (PP 600x1000)

- Represents standard features
- Represents optional features

## Standard and optional features

### Circuit breaker/power distribution

- 3-pole circuit breaker
- 4-pole circuit breaker
- Manual-actuated circuit breaker
- Electrical-actuated circuit breaker
- Stand-alone solution in separate cabinet

### Fuel system

- Flexible fuel connectors mounted to base frame
- Fuel filter with water separator
- Fuel filter with water separator heavy-duty
- Switchable fuel filter with water separator
- Switchable fuel filter with water separator heavy-duty
- Separate fuel cooler
- Fuel cooler integrated into cooling equipment

### Starting/charging system

- 24V starter
- Starter batteries, cables, rack, disconnect switch
- Battery charger

### Mounting system

- Welded base frame
- Resilient engine and generator mounting
- Modular base frame design

### Exhaust system

- Exhaust bellows with connection flange
- Exhaust silencer with 10 dB(A) sound attenuation
- Exhaust silencer with 30 dB(A) sound attenuation
- Exhaust silencer with 40 dB(A) sound attenuation
- Y-connection-pipe

Represents standard features

Represents optional features

## Weights and dimensions

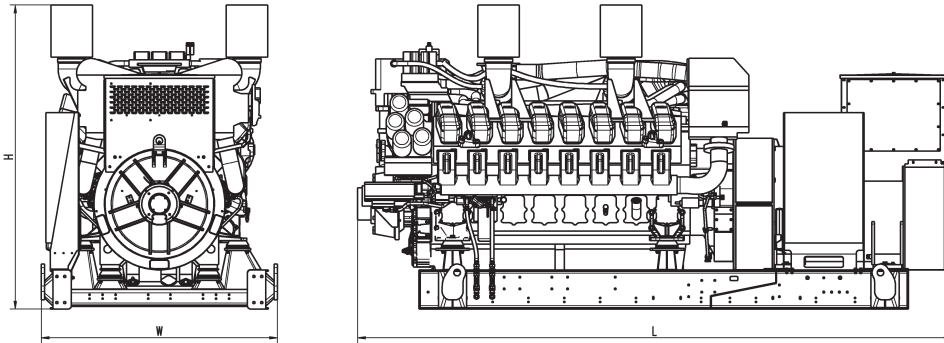

Drawing above for illustration purposes only, based on a standard open power 400 Volt engine-generator set. Lengths may vary with other voltages. Do not use for installation design. See website for unit specific template drawings.

System	Dimensions (L x W x H)	Weight (dry/less tank)
Open power unit (OPU)	4766 x 1810 x 2330 mm	13395 kg

Weights and dimensions are based on open power units and are estimates only. Consult the factory for accurate weights and dimensions for your specific engine-generator set.

## Sound data

– Consult your local MTU distributor for sound data.

## Emissions data

– Consult your local MTU distributor for emissions data.

## Rating definitions and conditions

- Grid Stability Power ratings apply to installations serving electric utility programs. At constant or varying load, the number of generator set operating hours is limited to 1000 hours per year with no more than 500 hours per year at 100% load without interruption. A 10% overload capacity is available for one hour in twelve. Ratings are in accordance with ISO 8528-1, ISO 3046-1, BS 5514 and AS 2789. Average load factor:  $\leq 100\%$ .
- Consult your local MTU distributor for derating information.